

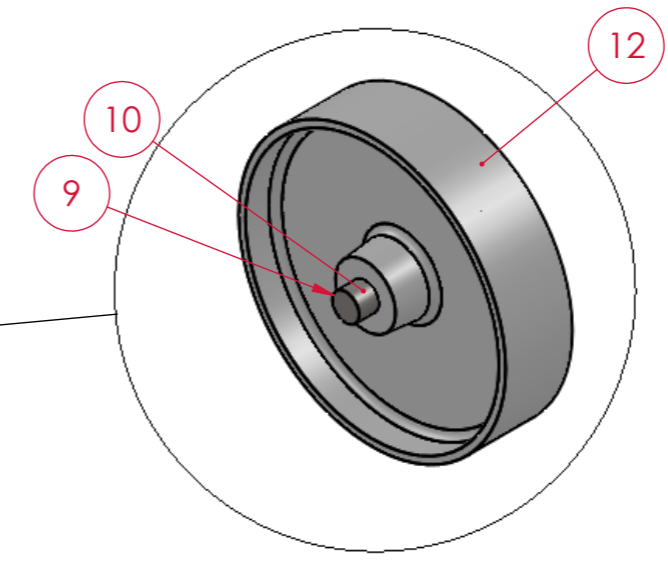



No. ARTICLE	NUMERO DE PIECE	DESCRIPTION	QTE
1	Rep5_D52-500	Tôle inox 304L brute 40/10	1
2	Rep1_D52-500	Plat inox 304L 80x10	1
3	Rep2_D52-500	Plat inox 304L 80x10	1
4	Rep3_D52-500	Plat inox 304L 80x10	1
5	Rep4_D52-500	Plat inox 304L 80x10	1
6	Rep6_D52-500	Tube inox 304L 30x30x1.5	1
7	Rep7_D52-500	Tube rond inox 304L ø30x1.5	1
8	Rep8_D52-500	Plat inox 304L 30x5	1
9	Axe roue_D52-500	Rond inox 304L ø20 lg 79	2
10	Plain Washer Normal Grade A_ISO		2
11	Roue pivotante frein ø100	Roue en polyamide blanc	1
12	Roulette ø200 polyamide	wicke : 850006 (ou équivalent)	2
13	ISO 4017 - M10 x 25-N		2
14	Washer ISO 7093 - 10		2



	Dessinateur:	Article: D52-500	Fichier: Z:\PLANS\SOLIDWORKS\D52 - ROULE BACS ET ROULE FUTS\STANDARD\D52-500 (fut ø600 avec poignée)\
	DIMITRO SAS 1, avenue Guy Denis 77910 VARREDES Tél: 01 64 35 02 61 Fax: 01 64 35 52 68 contact@dimitro.fr		
ROULE FUT ø600			Date: 09/02/2016
			Indice : O R

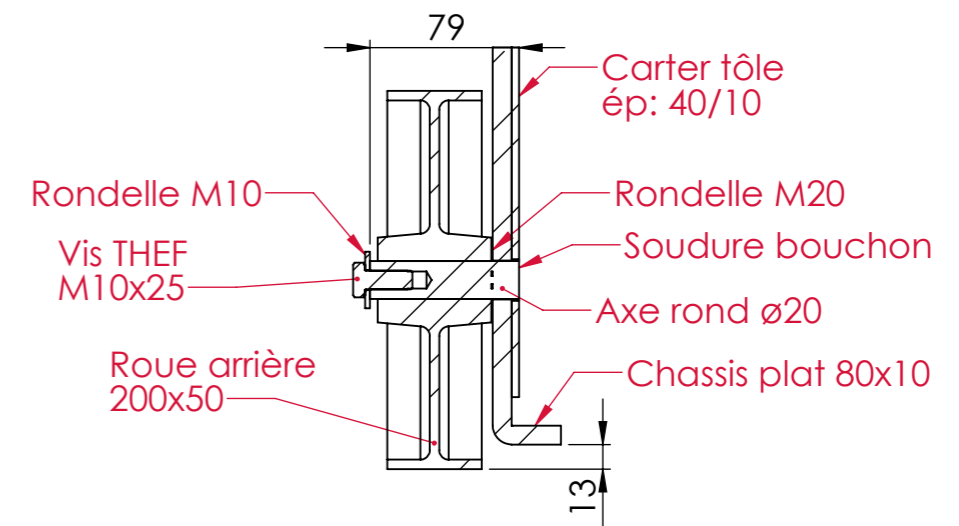
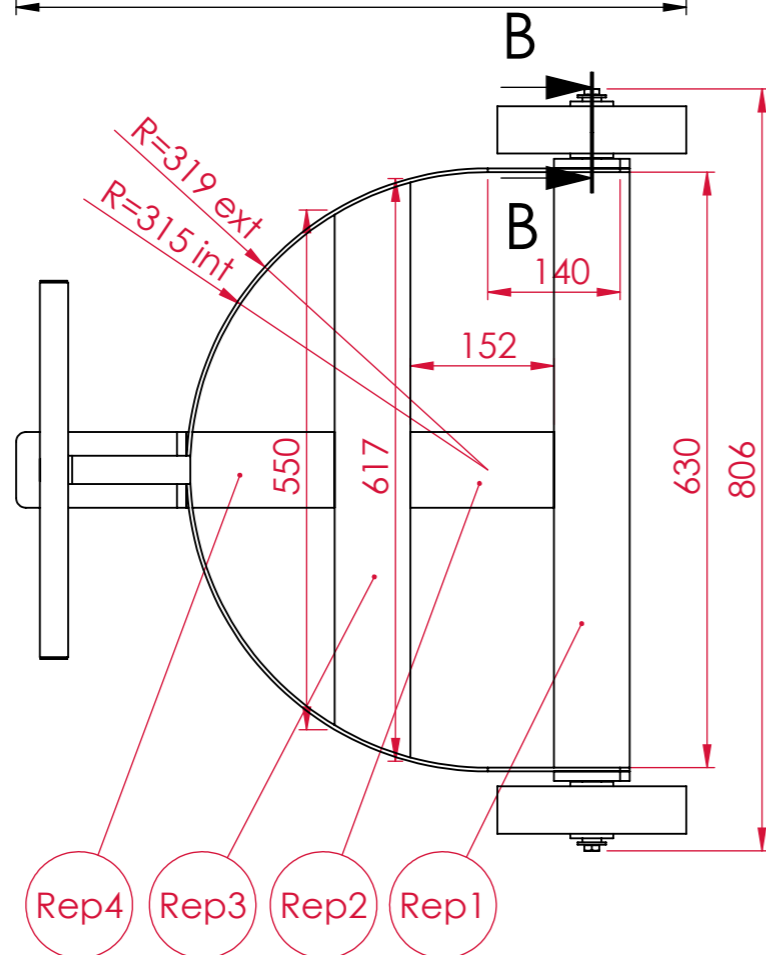
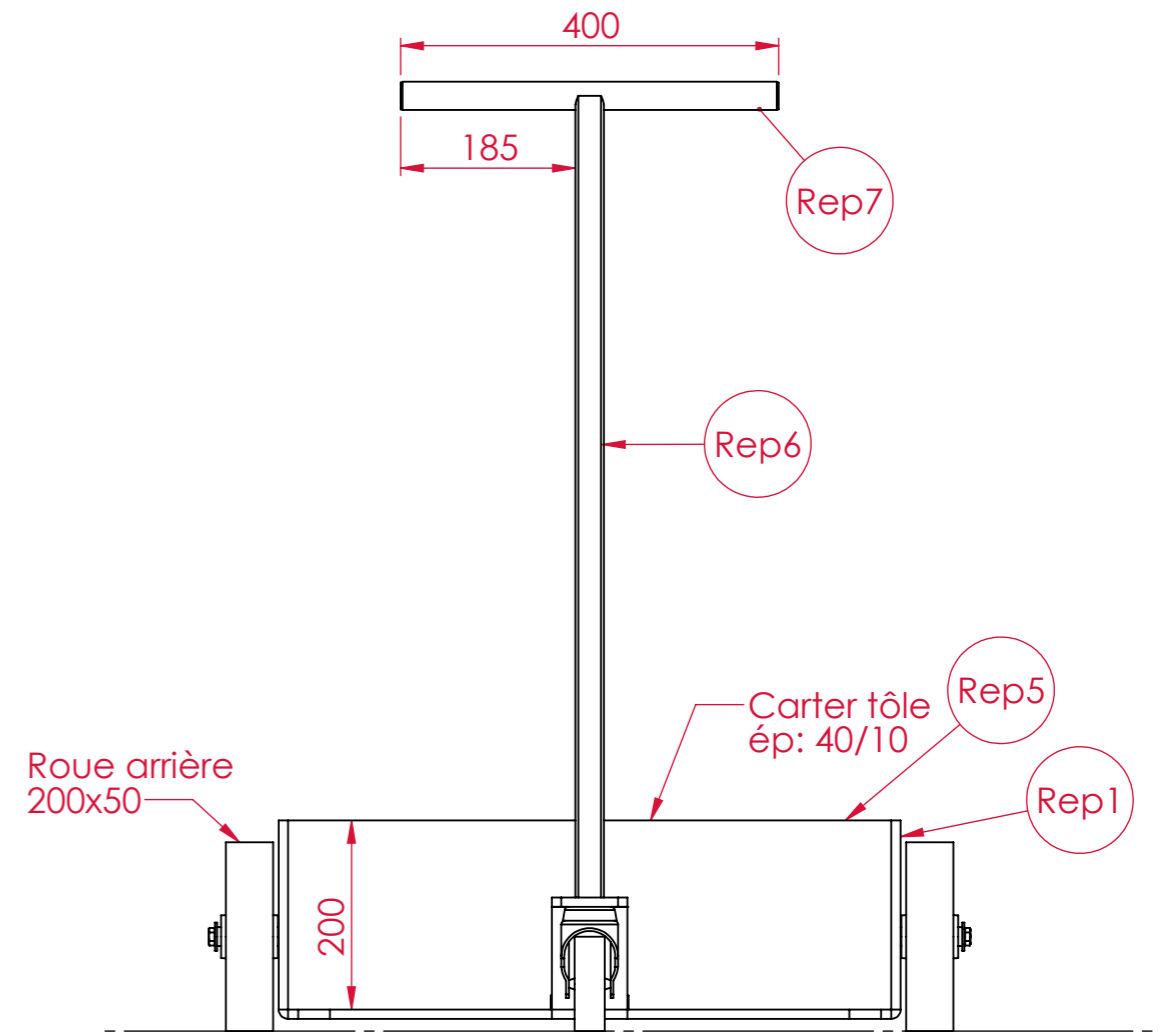
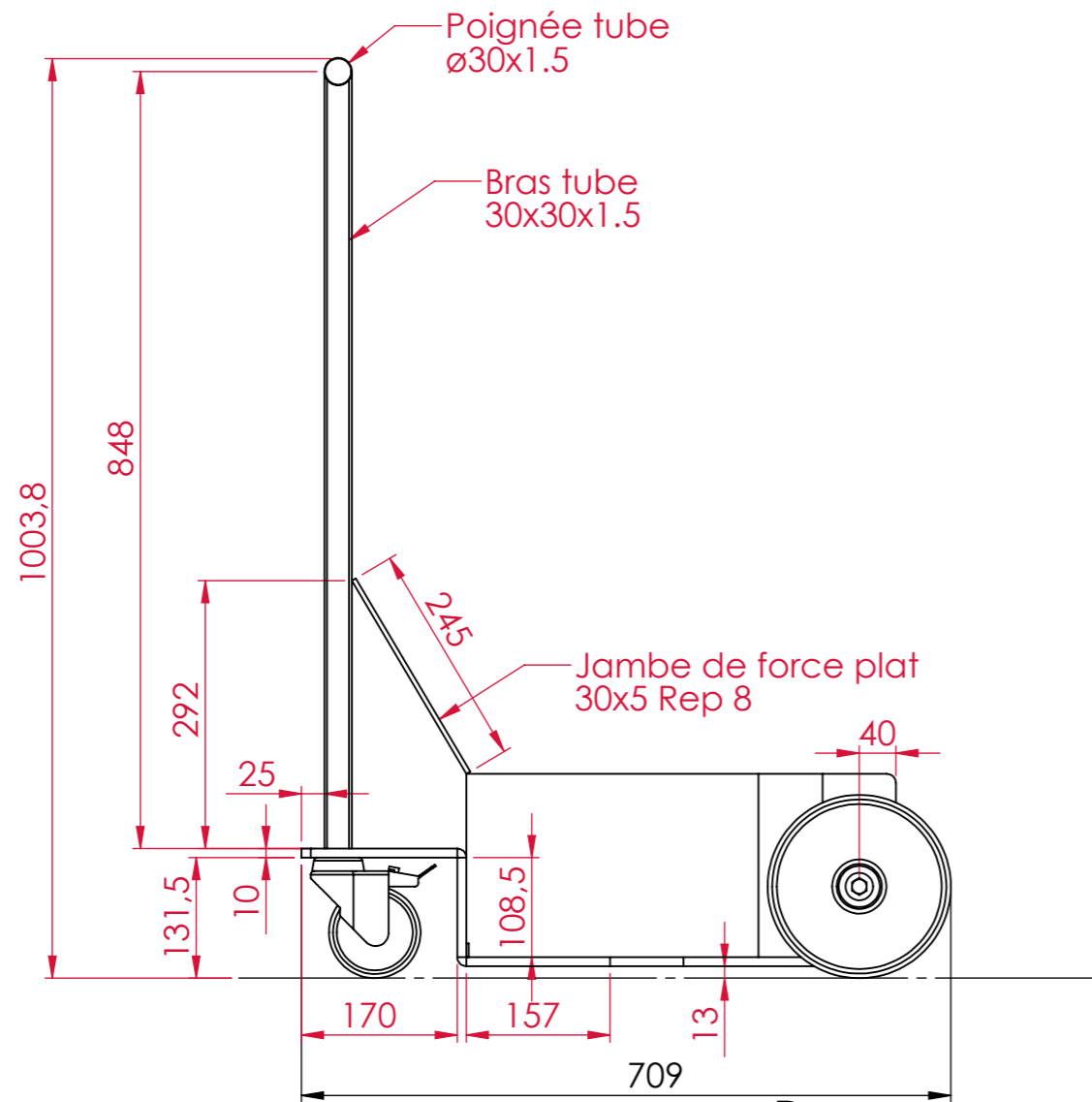

	Dessinateur:	Article: D52-500	Fichier: Z:\PLANS\SOLIDWORKS\D52 - ROULE BACS ET ROULE FUTS\STANDARD\D52-500 (fut ø600 avec poignée)\	Date: 09/02/2016
	DIMTECH SAS 1, avenue Guy Denis 77910 VARREDES Tél: 01 64 35 02 61 Fax: 01 64 35 52 68 contact@dimitro.fr		ROULE FUT ø600	Indice : O R